

doi:10.2478/mape-2021-0015

Date of submission to the Editor: 04/2021  
Date of acceptance by the Editor: 06/2021

MAPE 2021, volume 4, issue 1, pp. 166-177

## Magdalena Palacz

ORCID ID: 0000-0001-8369-5175  
Silesian University of Technology, **Poland**

## Tatiana N. Ivanova

ORCID ID: 0000-0003-2284-2949  
Tchaikovsky Branch  
“Perm National Research Polytechnic Institute”,  
Federal State Budgetary Institution  
of Science “Udmurt Federal Research  
Center of the Ural Branch of the Russian Academy  
of Sciences”, Institute of Mechanics, **Russia**

## Alexander M. Kozlov

ORCID ID: 0000-0001-7650-0616  
Lipetsk State Technical University, **Russia**

## Wojciech Kaniak

Rexroth Bosch Group Canada, **CANADA**

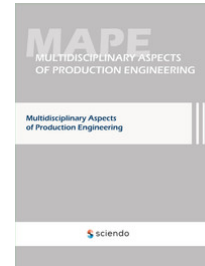

## INTRODUCTION

Strict requirements to the quality of production of parts are primarily determined by manufacturing technology on finishing operations. That is why decreasing labor input on production of parts and increasing labor productivity due to usage of more progressive machining methods are relevant tasks of mechanical engineering. This problem is especially relevant for face grinding of surfaces made of tough-to-machine materials.

## GRINDING HARD-TO-CUT SURFACES

The specific feature of grinding of tough-to-machine materials surfaces is high heat density in the zone of contact, which negatively impacts on formation of physical and mechanical properties of the machined surfaces. Heat density is a limiting factor for appointment of this operation in the structure of the technological process. As practical experience shows, application of rational compositions of cooling-lubricant technological fluids (CLTF), advanced methods and devices for their supply to the cutting zone are intrinsic and necessary element of technological support for operations of abrasive machining, providing many advantages. These advantages include optimal increase in work capacity of facer, decrease in heat density of the process, improvement of grinded surface quality and cutting modes (Patent 1997; Ivanova et al., 2018; Dement'ev et al., 2017; Ivanova 2016; Rezchikov et al., 2017; Nikitina & Polyakov, 2021; Troshin & Zakharov, 2020; Tambiev, 2018;

Nikiforov & Maltsev 2014).

Moreover, designing a tool for abrasive machining, which differs from standard ones, is one of possible directions for enhancement of technological prospects of grinding process. Creation of unsteady thermal mode, entailed by rapid periodical disruption of contact of the wheel with the machined surface and simultaneous supply of coolant gives an opportunity to change the time of thermal saturation decrease and vary the maximum temperature values in the contact zone due to creation of competitive tools (Fig. 1, 2) (Nosov et al., 2019; Tyuhta et al., 2016; Yanyushkin et al., 2017).

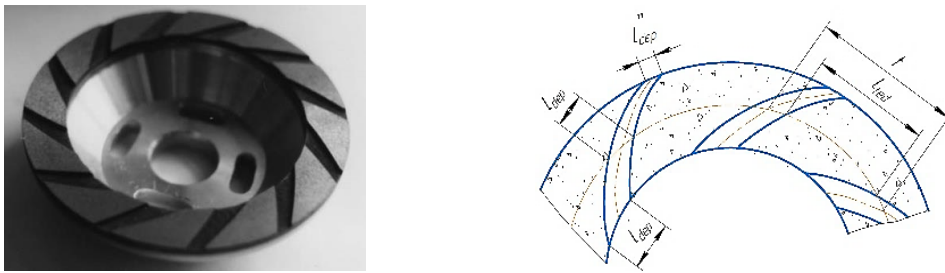

Fig. 1 Cutting surface of face grinding wheels

When studying thermal processes using tools (Fig. 1, 2) both with vortex air cooling and traditional liquid coolant we took thermal conductivity equation as a base. It is assumed that it corresponds to a scheme of moving strip source. Considering imposed boundary conditions for temperature distribution along the surface, which take into account temperature conductivity coefficient  $\alpha$ , speed of part  $u_{\text{part}}$ , machining length  $l$ , we obtained the next equation:

$$\theta_n = \sqrt{P_e^2 \cdot F_o} \cdot \left(1 - \Phi\left(\sqrt{P_e^2 \cdot F_o}\right)\right) - 0,564 \cdot \exp\left[\left(-P_e^2 \cdot F_o\right) - 1\right] \quad (1)$$

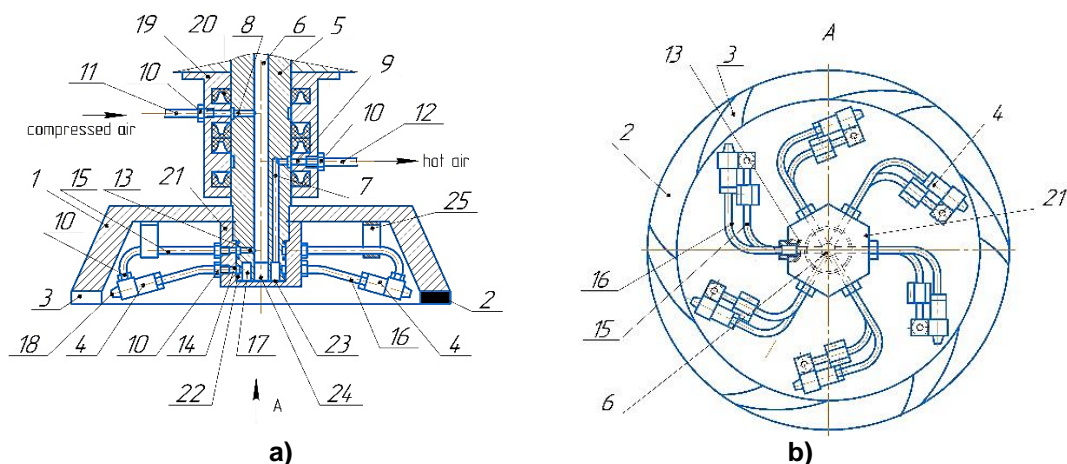

Fig. 2 Grinding tool with vortex air cooling: a) front view, b) bottom view from the side of abrasive layer. 1 – case, 2 – abrasive layer, 3 – grooves, 4 – vortex tubes, 5 – mandrel, 6 – concentric hole, 7 – hole, 8, 9, 13, 14 – radial holes, 10 – nuts, 11, 12 – pipelines, 15, 16 – pipelines, 17 – cavity, 18 – hole, 19 – coupling, 20 – packing seal, 21 – threaded sleeve, 22 – seal rings, 23 – gasket, 24 – screw, 25 – machine spindle.

It has been established that multiplying the square of Peclet number  $P_e = \frac{v_{part} \cdot l}{2a}$  by Fourier criterion  $F_o = \alpha \cdot \tau / l^2$ , characterizes the time of thermal saturation  $\tau$ . That is why dependence (1) allows us to determine time limiting maximum temperature in the surface layer of the machined part  $\theta_H$ , which causes irreversible phase transformations.

Under action of coolant the next dependence was obtained

$$\theta_{cool} = \exp\left(\frac{\alpha}{\lambda} \sqrt{a \cdot \tau_{cool}}\right)^2 \left[1 - \Phi\left(\frac{\alpha}{\lambda} \sqrt{a \cdot \tau_{cool}}\right)\right] \quad (2)$$

where:

$\alpha$  – heat exchange coefficient,

$\lambda$  – thermal conductivity coefficient of the machined material,

$\tau_{cool}$  – time considering supply of coolant in contact zone.

Fig. 3 demonstrates graphical dependence of equations (1, 2).

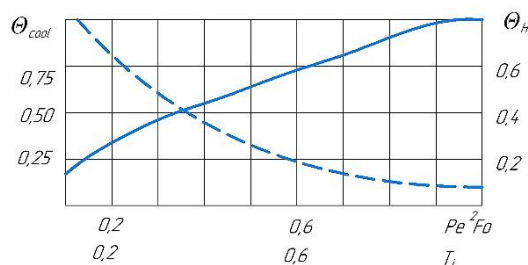

Fig. 3 Dependence of relative temperature:

$\theta_H$  on criteria  $Pe^2F_o$  (solid line),  $\theta_{cool}$  on cooling (dashed line), where:  $T_i = \frac{\alpha}{\lambda} \sqrt{a \cdot \tau_{cool}}$

Characteristic feature of dependences (1, 2) is the established influence of the radius of inclination of the grooves on tool cutting surface, number of vortex tubes, outflow rate, temperature and flow rate of cold vortex flow of air (table 1). It was established that temperature of machined surface decreases more intensively with an increase in length of groove, number of vortex tubes, and flow rate of cold vortex flow of air or CLTF.

Table 1 Parameters of the trajectory of movement of CLTF and cooled air along the cutting layer of the grinding wheel

Groove inclination angle $\varphi$ , rad	0	0.175	0.351	0.523	0.785	1.047	1.571
Groove inclination radius $r$ , mm	55.00	56.22	58.57	61.27	65.48	69.56	78.46
Air flowrate $G^*_{cool}$ , m <sup>3</sup> /s	0.008	0.010	0.015	0.015	0.026	0.010	0.010
Outflow rate of CLTF $v_f$ , m/s	11.29	14.67	14.96	15.89	15.82	15.23	15.23
Heat exchange coefficient $\alpha$ (W/m <sup>2</sup> -degree)	1016	1254	1273	1336	1332	1292	1292

To assess the reliability of obtained results, experimental research measurement of temperature in cutting zone was carried out by means of semiartificial thermocouple, installed in the machined part. Table 2 shows

calculated ( $T_{\text{teor}} \text{ } ^\circ\text{C}$ ) and experimental values ( $T_{\text{exp}} \text{ } ^\circ\text{C}$ ) of temperature during grinding using wheels with solid and discontinuous work surfaces. Figure 4 demonstrates comparison of the results with different cooling environment. The results of temperature field studies during face grinding by grooved tools with air cooling and jet supply of CLTF have shown that any coolant considerably reduces the penetration depth of high temperatures and total heat content of the part. It contributes to a decrease in temperature by 25-30% compared to tool with solid surface and supply of coolant by flooding

**Table 2 Study of temperatures**

Cutting modes			Grooved surface		Solid surface	
$v_{\text{part}}$ m/min	t, mm	$v_{\text{wheel}}$ , m/s	$T_{\text{teor}}$ $^\circ\text{C}$	$T_{\text{exp}}$ $^\circ\text{C}$	$T_{\text{teor}}$ $^\circ\text{C}$	$T_{\text{exp}}$ $^\circ\text{C}$
0.5	0.1	40	130	137	680	700
0.5	0.3	25	125	120	540	510
1.0	0.2	32	190	200	484	400
1.0	0.1	35	130	147	225	240
1.5	0.3	25	120	135	280	290
1.5	0.2	20	133	127	220	225
2.0	0.1	25	118	112	293	280
2.0	0.3	30	195	224	340	360
2.5	0.2	22	130	132	325	373

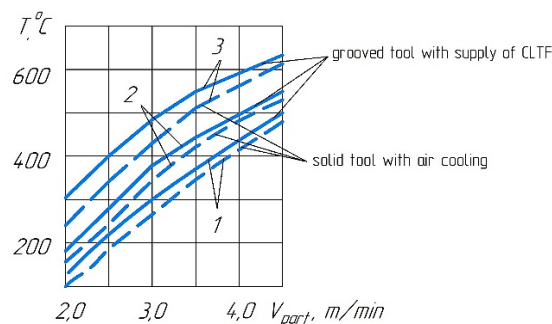
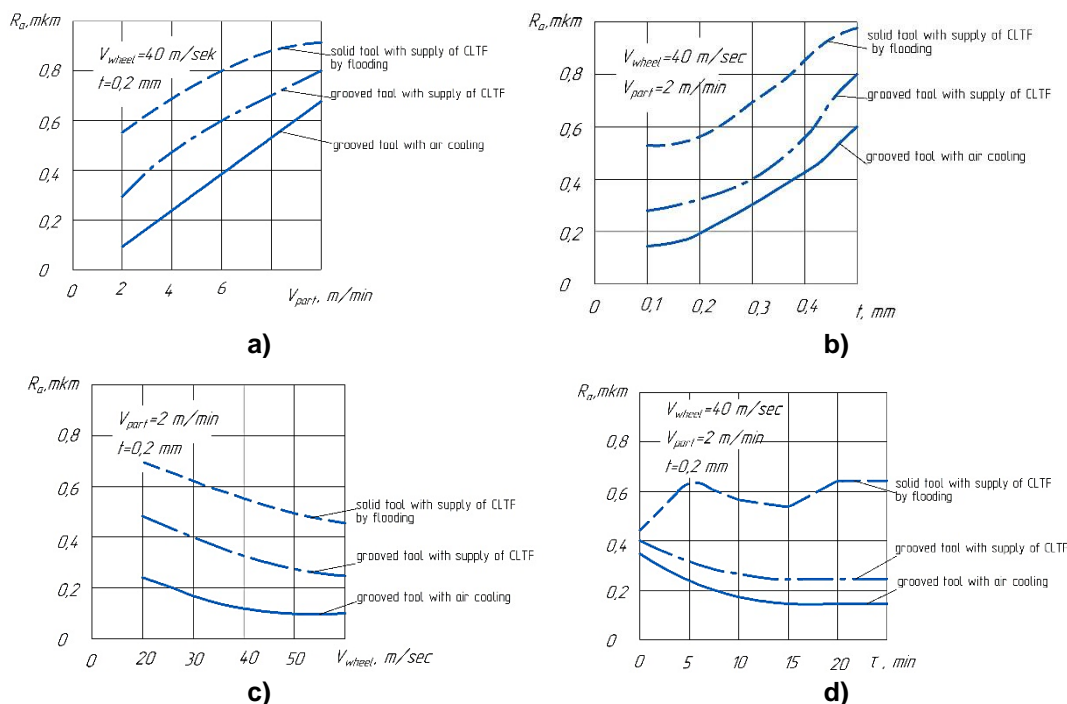

**Fig. 4 Dependence of contact temperature on speed of part  $v_{\text{part}}$  with grinding depth: 1 – t = 0,1 mm; 2 – t = 0,2 mm; 3 – t = 0,3 mm**

Other parameters, influencing the efficiency of grinding tool with vortex cooling, include cutting forces, roughness, physical and mechanical properties of the machined surface, metal removal and diamond consumption. For the sake of comparison, we have also conducted experiments on grinding with solid tool and supply of coolant by flooding. Experimental data have been processed according to experiment planning method. The results of the study include dependences of roughness, tangential and radial cutting forces, diamond consumption and metal removal intensity on cutting modes and grinding tool characteristics. Graphical dependences have been built to illustrate them (Fig. 4-6).

As you can see from Figure 5, in case of grinding with grooved tool with supply of cooled gas or liquid in the cutting zone, the grains acquire wear areas, which are typical for normal work of the wheel. What is more, the presence of such

wear character indicates that grains protrude from the bond, which holds them tightly, so they are less loaded. In case of solid wheel use, grains almost do not protrude.



**Fig. 4** Dependence of microroughness height  $R_a$  on a) speed of part, b) wheel speed, c) operation time, d) cutting depth when grinding steel 18KhN3A (Russia) with cooling. Grooves comprise 30% of wheel work surface. Tool 12A2 150x32x40 AC6 M2-01 4 (Russia)

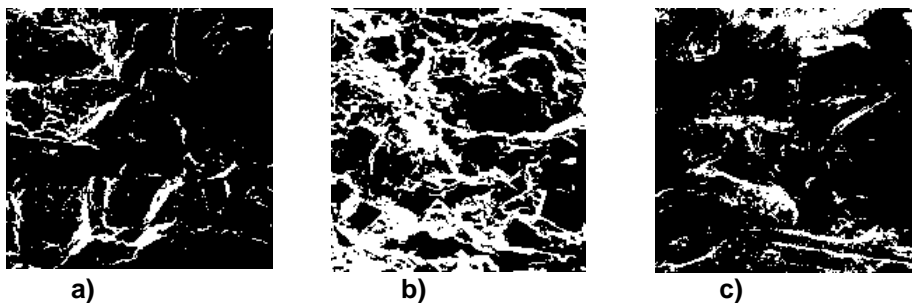
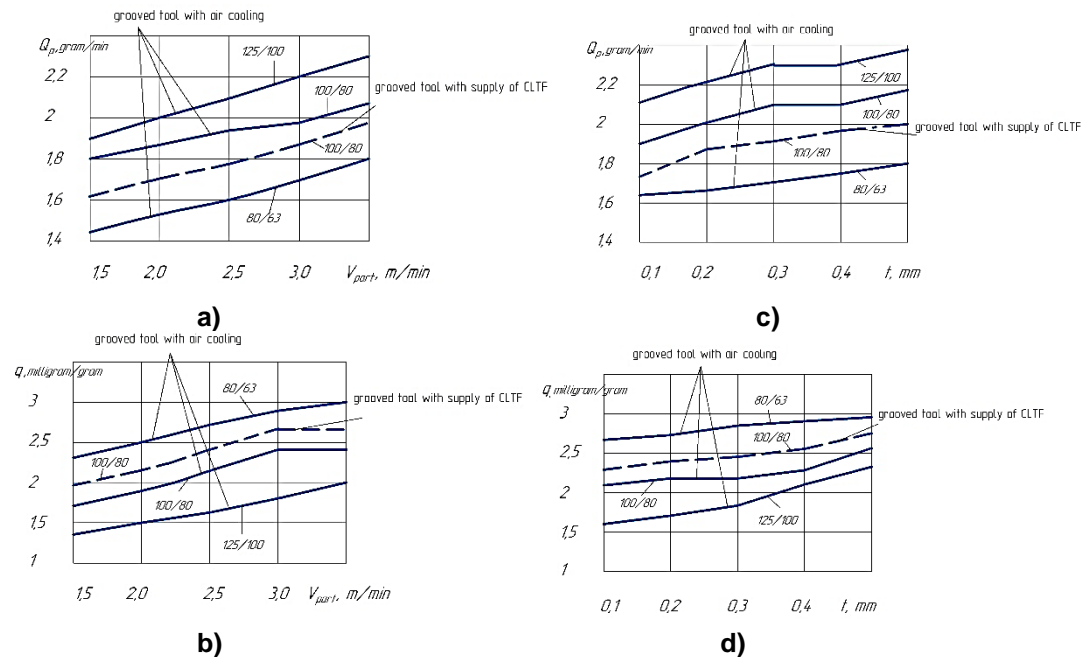

**Fig. 5** Cutting surface state: a) after 15 minutes of machining with grooved wheel and CLTF supply; b) after 15 minutes of machining with grooved wheel and vortex cooling; c) after 15 minutes of machining with solid wheel

$v_{\text{wheel}} = 40\text{m/s}$ ;  $t = 0,2\text{ mm}$ ;  $v_{\text{part}} = 4\text{ m/min}$ .

The analysis of obtained graphical dependences has demonstrated that machining with the grooved tool and coolant provides 30-40% decrease in roughness, 20-30% decrease in cutting force and 20-25% growth of wheel cutting ability in comparison with machining using standard tools. Firstly, it is explained by improved ability of grains to operate under considerable loads due to flow of coolant. Secondly, intensive flow of cooled air can serve as an agent of heat transfer from contact zone of grinding wheel with machined material. It contributes to creation of lower temperature in the plane of contact between

grinding wheel and machined surface, if compared to the use of cooling-lubricant fluid.



**Fig. 6** The influence of part speed and grinding depth on metal removal intensity (a, c) and specific diamond consumption (b, d) of grooved diamond tool with different grain size and vortex cooling and grooved tool with supply of CLTF INKAM-1 (Russia). Machined material – steel KhVG (Russia). Grinding tool 12A2 150x32x40 AC6 M2-01 4 (Russia). a, b)  $u_{wheel} = 40\text{m/s}$ ,  $t = 0,2\text{ mm}$ , c, d)  $u_{part} = 3\text{ m/min}$ ,  $u_{wheel} = 40\text{m/s}$ .

The bond of grinding tool with vortex cooling is protected from thermal destruction, so it holds the grains tightly and for longer period. Cutting forces, applied to a single grain, decrease. Therefore, there is an opportunity to create additional load on the grains, working with high speed. This can be reached by an increase in cutting depth or part speed, which allows growth of grinding productivity by 2-4 times. Supply of cold flow creates better conditions for heat removal from the surface of the part owing to intensive pouring of coolant through the grooves of discontinuous tool. It has been experimentally established that optimal ratio of shoulders to grooves should not exceed 30% of wheel work surface, while number of vortex tubes should be limited by 8. If these requirements are not fulfilled, it leads to worsening of roughness parameters and tool resistance.

It has been discovered that 4 zones can be formed in surface layers of steel during grinding:

- 1) austenitic-martensitic zone, an inhomogeneous weakly etched layer, which is found using metallography methods;
- 2) tempered martensite or ferrite, austenite and tetragonal martensite of secondary quenching;
- 3) ferrite and carbides;
- 4) zone of transition from high tempering structure to structure of initial thermal treatment.

All zones can occur in case of rough grinding modes, as for softer ones – only the third or the third and the fourth can form.

Studies have demonstrated that grinding of annealed steel leads to a rapid cold hardening of surface layer. Grinding modes, used in practice, result in ultimate hardening in surface layers of steels, which may result in crack propagation.

The samples of tough-to-machine steel 15Kh28 (Russia) of size 10x15 mm have been selected for experimental research on surface layer properties. After given thermal treatment, the samples were grinded by grooved diamond tool with vortex cooling and solid diamond tool with CLTF flooding under different grinding modes. Identification of samples microstructure was made by their etching in 4% solution of nitric acid in alcohol. Then the structure was studied and photographed by means of microscope. After this procedure, the microhardness was measured using the hardness meter. The results of microstructure studies are shown graphically (Fig. 7). Analysis of formed microstructures shows that when  $t = 0.1$  mm, deformed layer is insignificant, recrystallization is not observed. Only a certain degree of deformation contributes to the intensive growth of metal grains in the process of recrystallization. So, grain growth is observed after material deformation by 18-22%.

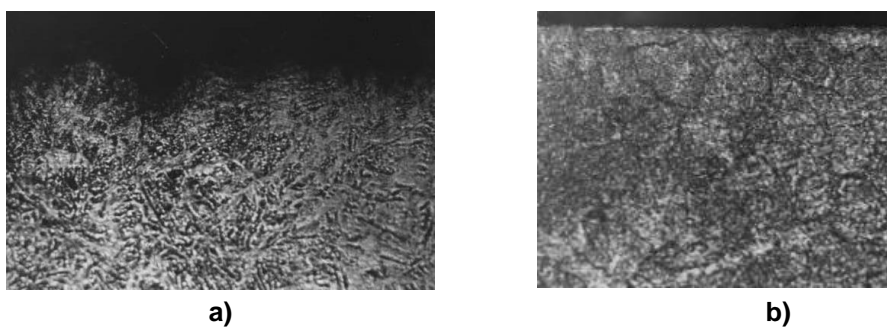

**Fig. 7** Microstructure of sample cross-section: a) grooved diamond tool with vortex cooling, b) solid diamond tool. x500. Tools A4K 150x32x40 and AC6 100/80 M2-01 4.

Research has shown that grinding with solid tool causes areas with burnings to grow in case of increasing cutting depth over 0.35 mm, which indicates surface layer tempering. At the same time, microhardness of surface layer also decreases. What is more, coarse grains of carbides, elongated along the machining direction, are observed. This phenomenon is connected with an increase in temperature in the cutting zone (Fig. 5, 6b). After removal of thin metal layer (3-4 microns) carbides of initial structure are formed, yet their cross-sectional size is 2-3 times bigger than on the initial surface

In case of grinding with vortex cooled tool, burnings are not observed on machined surface even when the depth is  $t = 0,4$  mm. There are small equiaxial carbides on the surface of the samples. It indicates that the temperature, generated in cutting zone, is not sufficient for the beginning of carbides plastic flow (Fig. 7a). The deformation of surface layer causes them to split. Transformations of surface layer with the change in depth of grinding are not observed.

The study of surface layer retained austenite has shown that its content remains the same along the depth of structurally changed layer in case of machining with solid grinding tool and cutting depth in the range of 0.1-0.4 mm. In other words, the content of retained austenite stays on the level, typical for initial structure of the sample. Grinding with vortex cooled tool leads to partial decomposition of retained austenite in the surface layer. This decomposition is distributed to a depth of 10-15 microns. Different distribution and the change of retained austenite content during grinding with solid and grooved tools indicates the differences in the nature of influence of these treatment types on surface layers of the machined material. If quenched steel is rapidly heated, the area of retained austenite decomposition shifts towards high temperatures. Therefore, rapid heating, entailing solid grinding, increases the resistance of retained austenite in surface layer. Increasing grinding modes leads to a growth of retained austenite content. Rising temperature intensifies the decomposition of retained austenite. That is why the observed decrease in austenite decomposition is not associated with thermal effects, yet it is the result of a decrease in the depth of the deformed layer with an increase in the grinding depth. In the process of grinding with solid tool, the removal of the chip is accompanied with deformation of metal along the edges of a scratch. As a result, surface layers are exposed to cold hardening. Due to an increase in cutting depth, chip formation ratio rapidly grows and the biggest part of cold hardened metal turns into chip. Underlying layers are exposed to less transformation due to friction of the diamond grain with metal surface

On the base of experimental data, obtained in this work, Table 3 was formed. It contains the data including metal removal per minute, microroughness height, wheel redress life during surface grinding of steel 45, steel KhVG, steel 13KhN3A (Russia) by solid face tool, grooved tool with air vortex cooling and grooved tool with injection of cooling-lubricant fluid INKAM-1. Steel grades are divided into groups; each group includes steels with similar grind ability. The indicators of the efficiency of grinding steels in different technological conditions are expressed in relative coefficients, since it is difficult to express accurate data on productivity, wheel resistance, machining accuracy in absolute terms:

Coefficient of wheel cutting ability

$$K_p = Q_M/P_y, \text{ mm}^3 \cdot \text{s}^{-1} \cdot \text{N}^{-1}, \quad (3)$$

where:

$Q_M$  – cutting ability of the wheel,  $\text{mm}^3 \cdot \text{c}^{-1}$ ;

$P_y, P_z$  – radial and tangential components of grinding force, respectively,  $10^2 \text{ N}$

Specific grinding power

$$K_N = N_g/Q_M \quad (4)$$

$$N_g = N_r - N_x \quad \text{W} \cdot \text{mm}^{-3} \cdot \text{s},$$

where:

$N_g$  – grinding power  $W$ ;

$N_r, N_x$  – load and idle power of the grinding wheel drive, respectively  $W$ .



Expression of these criteria through coefficients is sufficient for selection and correction of wheel characteristics and grinding modes. Actual values will depend on conditions of particular machining operation (machine and part stiffness, wheel size, machined surface and etc., which are usually taken into account in specifications on machining operations).

The coefficients, shown in the table below, allow us to see how metal removal, roughness and wheel resistance change with wheel characteristics, grinding mode and steel grade.

**Table 3 Criteria of technological efficiency of grinding**

Machined material	Criteria of technological efficiency						Cooling type
	Redress life $T_w$ , hours	Coeff. of wheel cutting ability $K_p$	Specific grinding power $K_N$	Roughness $R_a$ , microns	Radial force $P_y$ , $10^2$ N	Tangential force $P_z$ , $10^2$ N	
KhVG	1.00	0.91	0.86	0.63	0.95	1.03	(1) – CLTF «INKAM-1»
45	1.00	0.97	1.08	0.32	1.07	1.06	
13KhN3A	1.01	1.71	0.98	0.75	0.85	1.00	
KhVG	1.55	1.40	0.54	0.24	0.96	0.14	(2) – Cold air $T_{cool}^* = -5^\circ\text{C}$ , $p_{cool}^* = 0.3$ MPa, $\mu = 0.44$ , vortex tubes number – 6
45	1.91	1.11	0.80	0.10	0.91	1.0	
13KhN3A	1.20	1.33	0.82	0.18	0.63	0.84	(3) – Cold air $T_{cool}^* = 0^\circ\text{C}$ , $p_{cool}^* = 0.5$ MPa, $\mu = 0.36$ Vortex tubes number – 8
KhVG	1.42	1.07	0.31	0.26	0.93	1.10	
45	1.70	1.97	1.08	0.12	1.05	1.06	
13KhN3A	1.22	1.00	0.74	0.20	0.54	0.73	(4) – CLTF «AKVOL – 6»
KhVG	0.5	0.91	0.96	0.67	1.09	1.14	
45	0.9	0.89	0.93	0.32	0.87	0.99	
13KhN3A	1.02	0.99	1.50	0.63	0.91	1.05	

During grinding of samples of KhVG the highest value of redress life  $T_w$  and the lowest energy consumption  $K_N$  were reached in case of vortex air cooling in modes (2) and (3), respectively. Obtaining of the machined surface with minimum microroughness height  $R_a$  is possible in cooling mode (3). The highest values of  $R_a$  are obtained in case of use of CLTF «INKAM-1». The lowest force intensity and energy consumption ( $K_N$ ,  $R_a$ ,  $P_z$ ) are provided by cooling modes (2, 3, 1). CLTF «INKAM-1» and «AKVOL – 6» show the lowest intensity of wear of grinding wheel in case of machining steel 45. In case of grinding with cooling mode (2) the highest coefficient of wheel cutting ability  $K_p$  has been recorded. When grinding workpieces of steel 13KhN3A wheel redress life increase was provided in case of machining with vortex air cooling, mode (3). Machining with vortex air cooling is characterized by lowest force intensity and minimum energy consumption. Cooling mode (2) provided the best microgeometry of grinding

surfaces from steel 45 and the highest wheel redress life.

## SUMMARY

Using Table 4 you can select wheel characteristics for specific grinding conditions and if the first choice does not meet the requirements for this operation, final correction of wheel characteristics can be made.

**Table 4 Selection of wheel characteristics for diamond grinding of steels**

Steel grades	Grinding mode	Solid wheel		Grooved wheel with CLTF supply		Grooved wheel with vortex air cooling	
		100/80	80/63	125/100	100/80	125/100	100/80
		Cutting speed - 35 m/s		Cutting speed - 50 m/s			
Steel 45 Steel 20	Metal removal per minute	3.8	2.12	4.13	3.6	4.35	4.0
	Microroughness height	0.32	0.20	0.32	0.16	0.32	0.16
	Wheel redress life	1.88	1.82	2.96	2.07	3.45	2.6
KhVG	Metal removal per minute	2.34	2.39	3.09	2.8	3.66	3.28
	Microroughness height	0.4	0.32	0.38	0.2	0.38	0.2
	Wheel redress life	2.22	1.55	2.04	2.67	2.96	2.33
13KhN3A, 30KhSA, 20 KhN 3A	Metal removal per minute	2.0	1.55	3.82	3.45	3.93	3.62
	Microroughness height	0.32	0.2	0.32	0.16	0.32	0.16
	Wheel redress life	1.78	1.55	2.96	1.85	2.6	3.33

Let us explain how to use the table on the example of treatment of steel 45 by the wheel AC6 M2-01 100/80 with speed 35 m/sec. We assume that it is necessary to increase machining productivity significantly without worsening machined surface quality and wheel redress life. Using the first table line we find coefficients for the given conditions (average metal removal per minute – 3.8, microroughness height – 0.32, wheel redress life – 1.88). After this, we select new grinding conditions, which meet the requirement to increase the productivity. Such conditions for steel 45 include: grinding at speed 50 m/sec by grooved tool with vortex air cooling AC6 M2-01 125/100 (metal removal per minute – 4.35, wheel redress life – 3.45, microroughness height remains the same).

In practice, most often it is necessary to solve such problems. For example, if wheel resistance is not sufficient, it should be increased or solve the task of increasing the productivity of machining without worsening the quality of the machined surface. Obtained data provide conscious control over the process of discontinuous face grinding by changing wheel grain size and grinding speed.

## ACKNOWLEDGMENTS

*The article was written in support of BK-273/ROZ3/2021 (13/030/BK\_21/0065) research under the title "Department of Production Engineering' resources development for carrying out activities in the areas related to the Silesian University of Technology Priority Research Areas".*

## REFERENCES

- RF patent for invention № 2095227 / IPC 6 V 55/02, V 24 D 7/10 Abrasive tool for flat grinding / Svitkovsky F.Yu., Ivanova T.N., Kurko V.I., Osipova T.I. (Russia). Publ. 10.11.97 Bul. No. 31.
- Ivanova T N, Korshunov A I, Zavialov P M (2018) Influence of process fluids properties on component surface convective heat emission MEACS 2017 IOP Publishing IOP Conf. Series: Materials Science and Engineering 327 022051 doi:10.1088/1757-899X/327/2/022051
- Dement'ev V.B., Ivanova T.N., Dolginov A.M. (2017) Temperature of heating and cooling of massive, thin, and wedge-shaped plates from hard-to-machine steels during their grinding. Journal of Engineering Physics and Thermophysics. Vol. 90, Issue 1, pp. 102-109
- Ivanova T.N. (2016) Design and technology support of the grinding process for heavily-machined steel sheets. 2<sup>nd</sup> International Conference on Industrial Engineering (ICIE-2016) Edited by Andrey A. Radionov. Procedia Engineering. Vol. 150, p. 782 – 788 Crossref DOI link: <https://doi.org/10.1016/j.proeng.2016.07.112>
- Nosov N., Bobrovskij S., Levitskih O., Khaimovich A., Kanatnikov N., Metel A., Zaides S. (2019) Study of defects of the surface of rolls of rolling bearings under grinding. IOP Conference Series: Materials Science and Engineering 537, 032032
- Rezchikov A.F., Kochetkov A.V., Zakharov O.V. (2017) Mathematical models for estimating the degree of influence of major factors on performance and accuracy of coordinate measuring machines. MATEC Web Conf. Vol. 129, p. 01054.
- Tyuhta A.V., Vasilenko Y.V., Kozlov A.M. Ways to Enhance Environmental Flat Grinding by Improving the Technology of the Coolant Supply // Procedia Engineering 150 (2016) pp. 1073-1080 doi: 10.1016/j.proeng.2016.07.217
- Nikitina I.P., Polyakov A.N. (2021) Specific features of thermal processes in double-sided face grinding machines. Bulletin of Belgorod State Technological University named after V G Shukhov. Vol. 1, pp. 82-94
- Troshin A.A., Zakharov O.V. (2020) Classification of screw surfaces in cutting tool manufacturing. Geometric and computer modeling in training specialists for the digital economy. Materials of the International Scientific and Practical Conference dedicated to the 90th anniversary of the Saratov State Technical University named after Gagarin Yu.A. pp. 105-107.
- Tambiev M.Sh. (2018) Structural analysis of combined grinding wheels. In the collection: Progressive technologies and processes. Collection of scientific articles of the 5th All-Russian scientific and technical conference with international participation. Managing editor A.A. Gorokhov. pp. 246-250.
- Yanyushkin A.S., Lobanov D.V., Skeebeba V.Yu., Gartfelder V.A., Sekletina L.S. (2017) Enhancing the effectiveness of the diamond metal bond instrument when grinding high-strength materials. Metal Working and Material Science. Vol № 3 (76), pp. 17-27.
- Nikiforov I.P., Maltsev P.N. (2014) Optimization of the longitudinal feed during surface grinding structural carbon steel. Bulletin of the Pskov State University. Series: economic and technical sciences. Vol. 4, pp. 146-153.

**Abstract:** In current conditions, great attention is paid to the quality of parts, which is in many ways determined by finishing operations of mechanical treatment, with surface grinding being the most widespread. Grinding process efficiency, abrasive tool wear intensity, machined surface quality and other features of grinding process depend on properties of the environment, where the cutting process takes place. Forced changing of conditions of this environment is one of the ways to control and optimize the grinding process, which can be reached due to finding new technological decisions. One of the most promising directions to solve this problem is the process of face grinding with discontinuous grinding tool and supply of cooling fluid or air in the cutting zone directly. Carried analysis of features of face grinding has shown that heat density can be decreased by the usage by grooved wheels with vortex air cooling or by supply of cooling-lubricant technological fluid. Obtained dependences of temperature field of part surface during grinding establish the influence of the length of working shoulders and grooves, vortex tubes number, outflow rate, temperature and flow rate of cold vortex flow of air. These data provide conscious control over the process of discontinuous face grinding by changing wheel grain size and grinding speed.

**Keywords:** face grinding, grinding wheel, steel, vortex air cooling, cooling-lubricant technological fluid