

## STRUCTURE'S DAMAGE DETECTION SUPPORTED BY CONTACT AND CONTACT-LESS GLOBAL METHODS

Piotr KOHUT<sup>a</sup>, Krzysztof HOLAK<sup>b</sup>, Krzysztof MENDROK<sup>c</sup>, Wojciech MAJ<sup>d</sup>  
AGH University of Science and Technology, Department of Robotics and Mechatronics,  
Al. A. Mickiewicza 30, 30-059 Krakow, Poland  
<sup>a</sup>pko@agh.edu.pl; <sup>b</sup>holak@agh.edu.pl; <sup>c</sup>mendrok@agh.edu.pl; <sup>d</sup>wojtekm@poczta.fm

### Abstract

The paper briefly describes two Structural Health Monitoring (SHM) systems applied for damage detection in civil engineering structures: the vision-based system for in-plane measurement of a structure's displacement fields, and vibration-based SHM system with modal filter as a core component.

In vision-based system, the deflection curve is obtained as a result of analysis of two images of the construction: the reference one and the one acquired after application of the load. A modal filter is also an excellent indicator of damage detection, with such advantages as low computational effort, ease of automation and low sensitivity to environmental changes. To apply this method in a real SHM system, the measuring diagnostic unit has been designed and built. The system installed on the test stand consisted of a network of a sensors, needed by modal filtration system, placed in selected area of the structure. Additionally a linear transducer for measurement of deformation of the lower beam of the structure under investigation was used. The paper shows the results of their laboratory tests on truss structure. The experimental results obtained by both systems were compared.

Keywords: digital image correlation, image registration, vision systems, optical measurement system, deflection measurement, modal filter, damage detection, laboratory testing, truss structures.

### WYKRYWANIE USZKODZEŃ KONSTRUKCJI Z WYKORZYSTANIEM GLOBALNYCH METOD KONTAKTOWYCH I BEZKONTAKTOWYCH

#### Streszczenie

Artykuł opisuje dwa systemy monitorujące stan konstrukcji (SHM) wykorzystane do wykrywania uszkodzeń konstrukcji inżynierii lądowej: system wizyjny przeznaczony do dwuwymiarowych pomiarów pól przemieszczeń konstrukcji, oraz system oparty na filtracji modalnej.

W systemie wizyjnym krzywa odkształcenia uzyskiwana jest w wyniku analizy dwóch zdjęć obiektu: obrazu odniesienia oraz zdjęcia obiektu obciążonego. Filtr modalny jest doskonałym wskaźnikiem detekcji uszkodzeń. Jego zaletą są niskie wymagania obliczeniowe, łatwość automatyzacji oraz mała wrażliwość na zmiany środowiskowe. Metoda ta została opisana i przetestowana numerycznie przez autorów. Aby zastosować ją w rzeczywistym systemie SHM zaprojektowano specjalny moduł diagnostyczno – pomiarowy. System zainstalowany na stanowisku składał się z grupy czujników wymaganych przez system filtracji modalnej umieszczonych w wybranym obszarze obiektu. Ponadto wykorzystano czujnik LVDT do pomiaru odkształcenia liniowego dolnej belki. Systemy zostały przetestowane na rzeczywistych konstrukcjach. Artykuł przedstawia wyniki testów laboratoryjnych na laboratoryjnej konstrukcji ramowej. Wyniki eksperymentu uzyskane za pomocą obu systemów zostały ze sobą porównane.

Słowa kluczowe: cyfrowa korelacja obrazów, rejestracja obrazów, system wizyjny, optyczny system pomiarowy, pomiar odkształceń, filtr modalny, wykrywanie uszkodzeń, testowanie laboratoryjne, struktury kratowe.

## 1. INTRODUCTION

Structural Health Monitoring (SHM) is an emerging field of technology that involves the integration of sensors, data transmission, processing and analysis for detection, as well as localization and assessment of damage which can lead to its failure in

the future [1, 2]. In general, SHM methods can be divided into two groups: local and global ones. The second group can be applied if a global change in the geometry of a structure can be observed. In practice, the most commonly used methods of damage detection are based on the analysis of

variations in various dynamic properties caused by damage [3, 4].

One of the techniques from this group is an application of modal filtration to the object characteristics for damage detection purposes [21]. In this method system response is divided into components related with different modal shapes. If any change in object structure occurs, then a significant change in system response filtered by modal filter will be observed. This effect can be very useful for object damage detection purposes.

However, sometimes it is extremely difficult to attach sensors to a structure because of the geometrical constraints. What is more, the excitation of large structures can be costly and difficult. The acquisition of static deflection requires much less effort, which makes the damage detection methods based on changes in deflection curves more attractive for practical use [5-13]. Therefore, a lot of non-contact measurement techniques have been developed. The vision systems can be a good alternative to other types of transducers. They are easy-to-use, accurate and low-cost tools which can be applied to deflection measurements.

In this paper, two developed systems based on above mentioned principles are presented: the vision system for in-plane measurement of a civil engineering structure's displacement fields, and modal filtration based damage detection system.

The principle of the vision method is calculation of object's point displacement by means of a normalized cross correlation coefficient. Perspective distortions of the construction's image are removed by means of homography mapping, which allows two photographs of the object to be taken from two distinct points in space.

Second of mentioned systems is based on global change detection in the object. It consists of group of sensors located on examined object, and uses them to gather it's characteristics (PSD or FRFs). Those characteristics are then filtered by appropriately tuned modal filters, and used for damage index estimation. This approach was presented for the first time by Deraemacker and Preumont in 2006 [21].

There are discussed developed methodology and software tool for both systems. As a key study, girder deflection under a load has been investigated.

The experimental results obtained by both systems were compared.

## 2. VISION IN-PLANE DEFLECTION MEASUREMENT METHOD

In vision system, the deflection curve is obtained as a result of analysis of two images of the construction: the reference one and the one acquired after application of the load.

The proposed vision based method of the in-plane deflection measurement consists of three steps: image rectification, displacement field measurement and scaling. The first step of the

method is optional and can be performed if the images of the structure are taken from two distinct points in space. The rectified photograph can be spatially overlaid with the reference image. In the next step, the image of the construction's plane is divided into intensity patterns. The set of corresponding patterns is identified on the reference image and images of the structure deformed under the load by means of the normalized cross correlation coefficient (NCC). The deflection curve is computed as the difference between positions of the corresponding image patches on two images. In the last step, the scale coefficient is calculated from objects with known geometric dimensions.

### IMAGE RECTIFICATION

Homography transformation [16] has been introduced for reduction of perspective distortions which enabled a deflection's course to be obtained from images of a construction taken from distinct points of view. If coplanar corresponding points'  $\mathbf{x}$  and  $\mathbf{x}'$  positions are given in homogenous coordinates, homography can be represented by a 3-by-3 matrix denoted as  $\mathbf{H}$ . The transformation which maps coplanar points on the image with projective distortions to corresponding points on the reference image is given by:

$$\mathbf{x} = \mathbf{H} \mathbf{x}' \quad (1)$$

The homography matrix  $\mathbf{H}$  is computed from a set of corresponding points. Four pairs of coplanar corresponding points are necessary and sufficient to compute matrix  $\mathbf{H}$  if no three of them are co-linear. The plane of the construction is rectified when all image points are transformed by homography mapping [16]. Results of the rectification performed on the image of the lab setup are presented in Figure 1.

### DISPLACEMENT MEASUREMENT

In the process of deflection measurement, the reference image of an unloaded construction is divided into random speckle intensity patterns [1,2]. Each of the patterns is matched with corresponding pixel subsets on the image of the loaded structure by means of the NCC coefficient (2).

$$NCC(u,v) = \frac{\sum_{x,y} (f_n(x,y) - \bar{f}_n)(f_d(x-u,y-v) - \bar{f}_d)}{\sqrt{\sum_{x,y} (f_n(x,y) - \bar{f}_n)^2 \sum_{x,y} (f_d(x-u,y-v) - \bar{f}_d)^2}} \quad (2)$$

Where:

$f_n(x,y)$  – intensity value for a pixel with coordinates  $(x, y)$  on the reference image;

$\bar{f}_n$  – mean value of the intensity function of the pattern on the image before deformation;

$f_d(x-u,y-v)$  – intensity value for a pixel with coordinates  $(x, y)$  on the image after deformation;

$\bar{f}_d$  – mean value of the intensity function in the analyzed region after deformation;

$x, y$  – position of the pattern on the reference image;  
 $u, v$  – displacement of the pattern between two images;

The displacement vector is computed as the difference between positions of the pattern on two images. The method performed on each of the points of interest provides a complete course of deflection.



Fig. 1. Homography transformation: the reference image, the image with perspective distortion ( taken by the second camera), the second image after rectification

### SYSTEM CALIBRATION AND SCALING

The full camera calibration is carried out by means of the method developed by Zhang [17] to obtain the intrinsic parameters as well as coefficients for lens distortions correction. The chessboard planar pattern with black and white squares, an even number of rows and odd number of columns is used. The scale coefficient  $\alpha_{\text{mm/pix}}$  is computed from an object on the scene with known geometric dimensions, a planar circular marker or the certified length standard.

### DEVELOPED SOFTWARE TOOL

The developed software (Figure 2) enables construction deflection measurement using digital SLR cameras for remote image acquisition and provides image processing algorithms to calculate the displacement field. ED-SDK libraries provided by Canon have been used to control one or more cameras in the system. Two modes of operation are available: on-line and off-line. In the first case, the user specifies the date and number of measurements and then the system works fully automatically carrying out the image acquisition and deflection measurement. The off-line mode provides analysis of the images stored on hard disk.

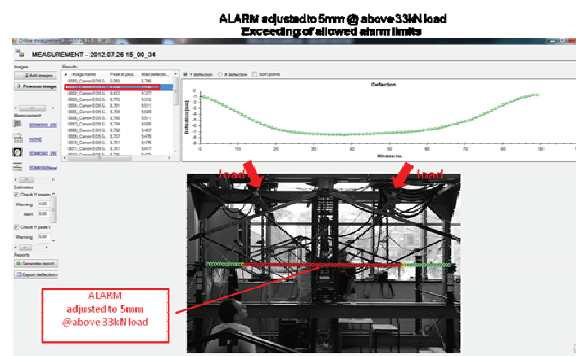

Fig. 2. Wiz2D Deflection - example form conducted tests during damage of the structure

The result browser module carries out the visualization of calculated curves of deflection and report generation in popular formats, like PDF, XML, CSV and TXT. An additional feature of the software is detection of exceeding the allowed level of a deflection and the sending of alerts to a client by an e-mail.

### 3. MODAL FILTRATION AS VIBRATION BASED METHOD OF DAMAGE DETECTION

The vibration based methods are one of the widest described damage detection methods [24]. One of the techniques from this group is an application of modal filtration to the object characteristics. A modal filter is a tool used to extract the modal coordinates of each individual mode from a system's output [25, 26]. It decomposes the system's responses into modal coordinates, and thus, on the output of the filter, the frequency response with only one peak, corresponding to the natural frequency to which the filter was tuned, can be obtained. Very interesting way of using modal filtering to structural health monitoring was presented by Deraemaeker and Preumont in 2006 [21] Frequency response function of an object filtered with a modal filter has only one peak corresponding to the natural frequency to which the filter is tuned. When a local change occurs in the object – in stiffness or in mass (this mainly happens when damage in the object arises), the filter stops working and on the output characteristic other peaks

start to appear, corresponding to other, not perfectly filtered natural frequencies. On the other hand, global change of entire stiffness or mass matrix (due to changes in ambient temperature or humidity) does not corrupt the filter and the filtered characteristic has still one peak but slightly moved in the frequency domain. The method apart from the earlier mentioned advantages, which results from its low sensitivity to environmental conditions has very low computational cost, and can operate in autonomous regime. Only the final data interpretation could be left to the personnel. This interpretation is anyhow not difficult and it does not require much experience. Another advantage of the method results from the fact that it can operate on the output only data.

### GENERAL ASSUMPTIONS

As it was mentioned in the previous section the modal filtration can be a great tool for damage detection and further for structural health monitoring. For this reason the authors decided to implement as a practical measuring – diagnostic system. Its main assumption was that it should be completely independent. It means that the potential user should be able to perform full diagnostic procedure without necessity of usage of any additional measuring device or software. To fulfill above requirement the original 16-teen channel measuring – diagnostic unit MDU was designed and the dedicated modal analysis and modal filtration software was written. Generally the system composed of both hardware and software is supposed to work in one of the three modes:

- I. Operation in dynamic signal analyzer mode for the purposes of the modal testing. In this mode the modal filter coefficients are estimated for the reference structure.
- II. Operation in diagnostic mode:
  - Acceleration / displacement of vibration measurements,
  - Selected characteristics estimation (FRFs or PSDs),
  - Modal filtration of the above characteristics,
  - Damage index calculation,
  - Visualization of the filtered characteristics,
- III. Operation in monitoring mode:
  - Periodical acceleration / displacement of vibration measurements,
  - Selected characteristics estimation (FRFs or PSDs),
  - Modal filtration of the above characteristics,
  - Damage index calculation,
  - Reporting of the object to the central unit.

### MEASURING DIAGNOSTIC UNIT

From technical point of view the diagnosis process is divided into a few basic steps:

- simultaneous synchronous acquisition of analog signal (converted into digital domain) from 16 channels.
- digital signal processing applied to measured signal
- output processing results

The block diagram of MDU is described in Figure 3.

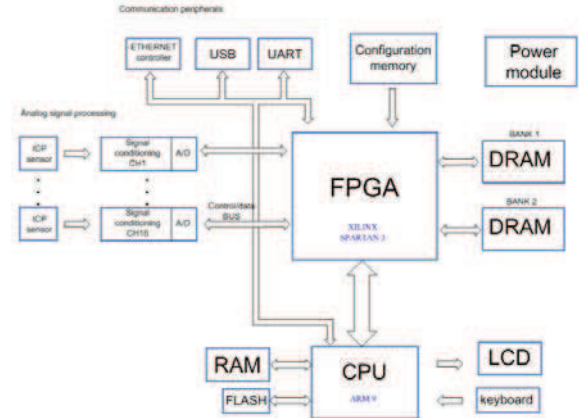

Fig. 3. Block diagram of design device

Diagnostic device contains of two fully independent and connected with each other modules: CPU and FPGA modules. The CPU module is included for control purposes – it implements user interface with some peripheral devices like keyboard, LCD display and communication peripherals. Using this interface it is possible i.e. to set gain or select required analog filter in each of 16 analog signal processing modules, or to start diagnostic process.

The FPGA module contains all logic modules needed for implementation of required digital signal processing. It is “seen” by CPU module as another peripheral device which can execute commands (like start data processing command) and send processing results.

In other words, the FPGA module act as a coprocessor, which shortens time necessary for full measure cycle and therefore allow for power savings.

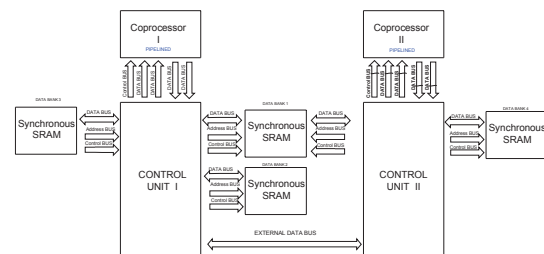

Fig. 4. FPGA processing module block diagram

The FPGA data processing module is designed using multi path, pipelined architecture (figure 4), which can be easily extended to support more signal channels, and less processing time as required.

MDU also contains non-volatile memory for data recording purposes.

The MDU can be accessed via Ethernet or USB, which is needed in system calibration phase, or to read remotely processed results. Analog signal processing module is shown in figure 5.



Fig. 5. Analog part of the circuit measuring

The input analog signal is delivered from ICP accelerometer sensors mounted on examined object. ICP signal standard is based on 4 – 20 mA current signal transmission, which main advantage is the ability of transmitting signal (with 1 kHz frequency band wide) without any distortion at ranges of 100 m and more.

Analog signal processing circuit also contains programmable gain amplifier (PGA) for three different values of gain: 1, 10 and 100. It also includes a set of analog antialiasing filters (with cutoff frequency set to: 10Hz, 50Hz, 250Hz, 500Hz and 1kHz) and 24-bit ADC converter.

MDU contains 16 identical analog signal processing channels, each for every analog input. The ADCs of every data channel are configured to provide synchronous signal acquisition, so that every sample gathered by first ADC is accurately synchronized in time with those coming from other ADCs.

With this hardware solution it is possible to detect and continuously monitor ICP status (whenever the input is shorted, opened or work in it is normal working conditions). It is also possible to detect input signal overshoots, so that device will not take such distorted data into account during measures.

## DEDICATED SOFTWARE

The main goal of the software written for the described SHM system is the estimation of the modal filter coefficients. For this purpose, the application provides the following functionalities:

- Geometrical model definition of the tested object.
- Measurement points definition, namely the assignment of specific points of a geometric model to the sensors placed on an object.
- Execution of measurement and presentation of the results (time histories, PSD, FRF and coherence), and data archiving.
- Execution of modal analysis by:
  - calculation of stabilization diagram,
  - estimation and visualization of mode shapes for selected poles,
  - estimation of modal filter coefficients and visualization of filtration results.

The application was created in the .Net Framework 3.5 environment with use of additional external libraries:

- Developer Express v9.1 (tables and standard application controls)
- Steema TeeChart for .Net v3 (charts)
- Intel IPP (signal spectrum calculation)

All calculations related to the modal analysis are performed by the Matlab engine. The application provides the ability to debug these functions from Matlab level. For this reason, at the user-specified location, mat-files are stored that contain input parameters for the appropriate Matlab functions. In Figure 14 the graphical user interface of described software allowing for impulse modal testing and mode shape visualization control is presented.



Fig. 6. GUI of described software

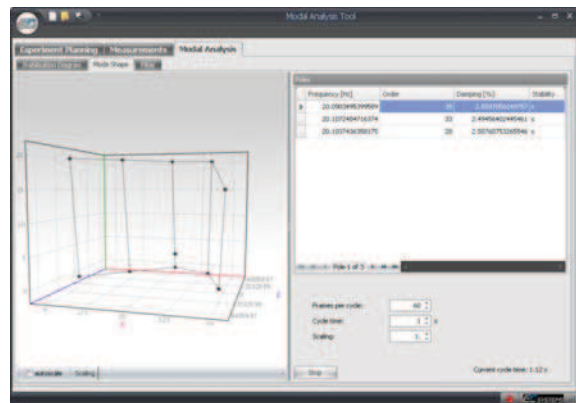

Fig. 7. GUI of described software

It was assumed that in order to fluently visualize the mode shapes it is necessary to refresh screen with a minimum speed of 30 fps. There are not available on the market sufficiently effective controls to allow the visualization and animation of 3D models with the assumed speed. Therefore, implementation of such control was done by using the XNA environment. The control uses a graphics accelerator which allows for refresh at 60 fps at 10,000 points of geometrical model.

#### 4. EXPERIMENTAL SET-UP AND PROGRAM OF TESTS

During the experiment a load was applied on a single girder shown in Figure 7 mounted on a specially built test stand [14, 15]. The experiment was carried out until the damage of the girder. Actuators, two hydraulic jacks, were used to apply the load on the truss. Experimental conditions imitated the real working conditions of the trusses typically used in roof constructions. Jack's mounting points on the construction were placed symmetrically in the middle of the upper truss members. During the experiment load cycles were applied to the construction. In each cycle load was slowly increased in several steps and later removed in the same manner.

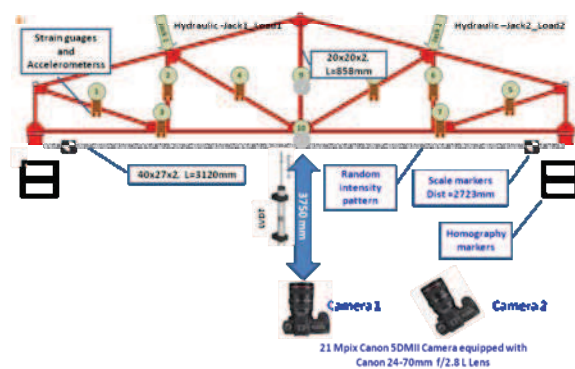

Fig. 8. Experimental set-up: a) transducer's and camera's arrangement on the girder. Dimensions of the bottom truss member: 40x27x3120 mm, dimensions of the vertical truss: 20x20x85 mm

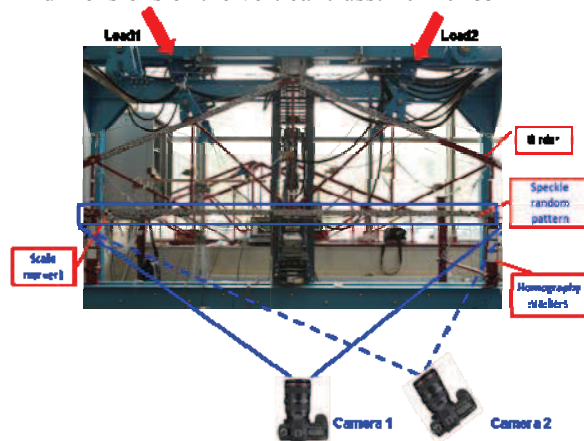

Fig. 9. Experimental set-up: camera's, scale markers, homography markers arrangement on the girder

Deflection of the bottom truss of the girder was measured by the developed vision system (Figure 8). The truss of length 3120 mm and member's cross section 40x27 mm was used. The beam was fixed at both ends. The texture characterized by random distribution of diameters and positions of oval patterns was stuck on the analyzed truss surface. The set of rectangular markers necessary for homography matrix computation was placed on the

both side of the truss. Photographs of the construction were acquired by a system of two digital Canon 5D Mark II cameras with 21.1 MPix image resolution and Canon 24-70mm f/2.8L lens with focal length  $f \approx 39$  mm adjusted. The position of the cameras were fixed. One of the cameras had its optical axis perpendicular to the plane of the construction. The reference images were obtained by that camera. The second camera was translated and rotated with respect to the first one and used for calculation of the deflection field from the images after application of rectification. The distance  $d_0$  of the reference camera amounted to 3750 mm. The distance  $d_1$  between the cameras was 960 mm and the angle between the optical axes of the first and the second camera amounted to 14.5 degrees. To calculate scale coefficient (0,5873 mm/pixel) the two crash-test markers were stuck on the truss at a known distance, 2723.5 mm. Regarding scene illumination, there were extremely changeable natural lighting conditions with sunlight and cloudy variations.

In order to detect object damages with modal filtering system, a set of vibration sensors were installed on bottom beam of the truss as shown in Figure 9. Each sensor is connected directly to the measurement system, so that the truss state was continuously monitored. A significant advantage of this approach is that it is not necessary to place a large number of sensors on examined object even if it is large. The user can place only a few sensors evenly distributed on the object. What is more, position of each sensor cannot be changed during measurements, as it would affect damage detection quality [27].

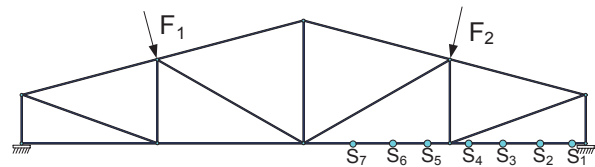

Fig. 10. Experimental set-up: Object of tests with sensors mounted on it

As a matter of fact this method can be successfully used in applications where the measures are performed periodically. In this case sensors doesn't need to be installed permanently, however user have to ensure that every sensor is mounted exactly in the same point of the object as it was during reference measure. This can be achieved by using dedicated spacers (between object and sensors) mounted permanently on tested object.

#### 5. VISION-BASED MEASUREMENT RESULTS

The repeatability of the vision based measurement method has been carried out for both cameras in the system. There were no significant difference of the standard deviation of the measured

displacement between the data obtained using reference camera and the camera the data computed after rectification. There was decrease of the repeatability observed with the increasing value of the load. The results are presented in table 1.

Table 1. Repeatability of the vision based measurement method

Force [kN]	Reference [mm]	Rectification [mm]
5	0.0085	0.0085
10	0.0096	0.0102
20	0.0129	0.1278
25	0.0166	0.0209
30	0.0161	0.0191
35	0.0143	0.0157

**COMPARISON OF THE VISION BASED SYSTEM WITH LVDT MEASUREMENT**

The displacement computed in one point (Fig.10) by the vision system was compared with the value obtained by a contact measurement method using LVDT sensor. The absolute difference between two results ranged from 0.099 mm to 0.386 mm. The absolute difference between displacements registered by two systems is summarized in table 2. The figure 3 shows the displacement in a point as a function of applied load for vision system as well as contact type sensor.

Table 2 Absolute difference between vision and contact measurement

Force [kN]	Difference [mm]
5	0.1719
10	0.2623
20	0.2517
25	0.0292
30	0.3860
35	0.0997

**DAMAGE DETECTION BY THE DEVELOPED VISION SYSTEM**

The developed vision system monitors the state of the structure and informs the user when the measurement estimates has been exceeded and a message can be sent by email. In this matter the developed software tool enables damage detection based on the comparison measured data with the adjusted thresholds of the warning and alarm values. The visualization of the warning and alarm threshold exceed are illustrated in the Figure 11. Yellow-colored points represent warning and exceeded deflection values of the measurement points, while red-colored points indicate the alarm and exceeded deflection values of measurement points calculated by digital image correlation method.

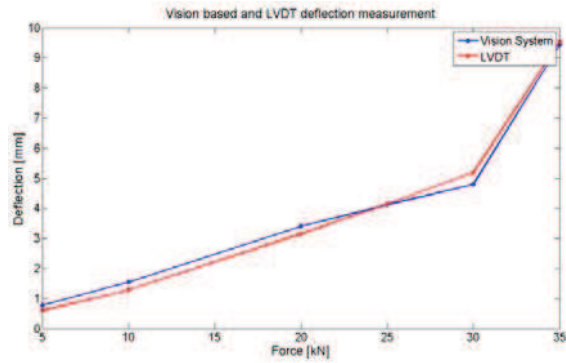

Fig. 11. The displacement in a point as a function of applied load for the vision system as well as contact type sensor

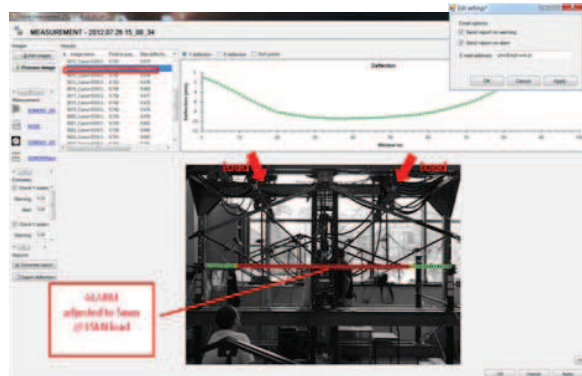

Fig. 12. Example of alarm thresholds' value exceeding (red color) indicating damage of the girder

**6. VIBRATION – BASED MEASUREMENT RESULTS AND COMPARISON WITH VISION SYSTEM RESULTS**

During the experiment, load was slowly increased in several steps, until the first symptoms of damage appeared. As an input to the diagnostic procedure based on modal filter only one type of characteristics was considered: FRFs. All the results were evaluated with use of damage index proposed in [28]:

$$DI = \frac{\int_{\omega_s}^{\omega_f} |x_i(\omega) - x_{ref}(\omega)|^2 d\omega}{\int_{\omega_s}^{\omega_f} x_{ref}(\omega)^2 d\omega} \quad (3)$$

where:

$\omega_s, \omega_f$  – starting and closing frequency of the analyzed band,

$x_i, x_{ref}$  – characteristic in the current and reference state respectively.

The measure results are presented in Table 3.

Table 3. Modal filtration system measure results

No	Measure Results			comment
	DI[0]	DI[1]	DI[2]	
1	1.46E-02	4.53E-02	2.82E-02	REFER. F=0kN
2	8.07E-01	8.17E-01	4.00E-01	F=5kN
3	8.83E-01	7.59E-01	4.80E-01	F=10kN
4	9.60E-01	9.24E-01	6.98E-01	F=20kN
5	1.03E+00	1.11E+00	7.52E-01	F=25kN
6	1.11E+00	1.30E+00	8.31E-01	F=30kN
7	<b>1.44E+00</b>	<b>1.31E+00</b>	<b>1.34E+00</b>	<b>F=35kN</b>
8	8.54E-01	8.71E-01	7.10E-01	F=15kN
9	2.07E-01	4.39E-01	3.50E-01	F=0kN
10	1.35E+00	1.16E+00	1.13E+00	F=35kN

For every measure there are three damage index values calculated for different modal filter. Measurement no. 1 was performed in object reference state. We can notice relatively small values, which may lead to conclusion that there is little or no change in truss internal structure since the reference measure was done.

Next step was to increase value of force applied to the object and measure damage index values for each step. As we can see in Table 3, larger force values means higher damage index values. This fact fully agree with theory, as internal structure stress have an impact on modal response.

The load was increased up to the value of 35 kN, when the object started to deflate.

The object deflation was confirmed by vision system measurements used in parallel during tests. If we look again at characteristics shown in Figure 10 we can see a bend in both load curves around the point where load with value of 30kN was applied. This suggests internal truss structure change.

After that a value of force was step-by-step decreased up to the point where no force was applied to the object. Looking at Table 3 we can easily notice the difference in damage index values between measurements 1 and 9.

If there were no internal change in the structure of truss, measured damage index values would be similar. However, these values are over 10 times greater, which means that internal structure of truss had changed. This conclusion had been confirmed by measures, as the object remained deformed after load removal (Figure 12).



Fig. 13. Deformed truss in the point of jack mounting

## CONCLUSIONS

Deflection and displacement measurements are valuable indicators of the state of analyzed structures. Displacement of points can point to elongation or shortening of the structural members due to temperature change, breaking loads or a damage. Multimodal sensor integration (strain gauges and LVDT) in the SHM system allowed to reveal an unexpected deflection increase and to detect a damage within the girder. Main advantages of the vision techniques application are high measurement density, the possibility of carrying out global examination of the object's state, flexibility, universality and low cost. The measurements are carried out contactless and without introducing undesirable changes in its dynamical properties like additional masses or stiffness.

Second of tested systems is based on modal filtration of system characteristics. This obviously involves need of installing sensors on tested object. However there is no need to apply a large number of sensors even on large objects. The system in general detects damage with good sensitivity (as confirmed by used in parallel vision system), however the sensors should not be replaced during system operation, as this could affect measurement results.

The performed research has confirmed the applicability of vision-based technique and modal filtration based method to evaluate the engineering structures' state and to detect the presence of a damage.

## ACKNOWLEDGEMENT

Research funding from the Polish research project MONIT (No. POIG.01.01.02-00-013/08-00) is acknowledged by the authors

Authors would like to express their special thanks to Professor Stanislaw Radkowski, dr Jędrzej Mączak and A. Gałęzia for the possibility to make measurement on the stand in Warsaw University of Technology.



## REFERENCES

- [1] T. Uhl, P. Kohut, K. Holak, *Prototype of the vision system for deflection measurements*. Diagnostyka (4), 3–11, 2011
- [2] T. Uhl, P. Kohut, K. Holak, K. Krupiński, *Vision based condition assessment of structures*, Journal of Physics, Conference Series, vol. 305 (2011) pp. 1–10
- [3] P. Kohut, P. Kurowski, *The integration of vision based measurement system and modal analysis for detection and localization of damage Engineering achievements across the global village*, The International Journal of INGENIUM, pp. 391–398, 2005
- [4] P. Kohut, P. Kurowski, *The integration of vision system and modal analysis for SHM applications Proceedings*, Of the IMAC-XXIV a conference and exposition on structural dynamics, pp. 1–8, St.Louis, USA, 2005
- [5] S. Jang, S. Sim, B. Spencer, *Structural damage detection using static strain data Proceedings of the World Forum on Smart, Materials and Smart Structures Technology*, China, 2007
- [6] H. J. Guo, Z. Li, *Structural damage detection based on strain energy and evidence theory*. Journal of Applied Mechanics and Materials 48–49, 1122–11256, 2011
- [7] X. Chen, H. Zhu, C. Chen, *Structural damage identification using test static databased on grey system theory*, Journal of Zhejiang University Science 6(5), 790–796, 2005
- [8] Dilena M., Morassi A., *Identification of crack location in vibrating beams from changes in node positions*, Journal of Sound and Vibration, Vol. 255, Nr 5, 2002, s. 915-930
- [9] H. J. Guo, Z. Li, *Structural damage detection based on strain energy and evidence theory*. Journal of Applied Mechanics and Materials 48–49, 1122–11256, 2011
- [10] X. Chen, H. Zhu, C. Chen, *Structural damage identification using test static databased on grey system theory*, Journal of Zhejiang University Science 6(5), 790–796, 2005
- [11] H. Li, H. Yong, J. O, Y. Bao, *Fractal dimension-based damage detection method for beams with a uniform cross-section*. Computer-Aided Civil and Infrastructure Engineering 26(3), 190–206, 2011
- [12] Hensman J., Surace C., Gherlone M., *Detecting mode-shape discontinuities without differentiation - examining a Gaussian process approach*, Journal of Physics: Conference Series 305, 2011, s. 1-10
- [13] S. Patsias, W. J. Staszewski, *Damage detection using optical measurements and wavelets*. Structural Health Monitoring 1(1), 5–22, 2002
- [14] A. Gałęzia, S. Gontarz, M. Jasiński, J. Mączak, S. Radkowski, J. Seńko, *Distributed system for monitoring the large scale infrastructure structures based on changes analysis of its static and dynamic properties*. Key Engineering Materials. Vol. 518, 2012, pp 106-118, 2012
- [15] J. Bajkowski, M. Jasiński, J. Mączak, S. Radkowski, R. Zalewski, *The active magnetorheological support as an element of damping of vibrations transferred from the ground to large-scale structure supports*. Key Engineering Materials, Vol. 518, pp 350-357, 2012
- [16] Hartley R., Zisserman A., *Multiple View Geometry in Computer Vision*, Cambridge University Press, 2004
- [17] Z. Zhang. *A flexible new technique for camera calibration*. IEEE Trans. Pattern Anal. Mach. Intell., 22 (11) (2000) 1330-1334
- [18] Holak K., Kohut P., Martowicz A., Uhl T., *An uncertainty analysis for developed measurement vision system aided by numerical simulations*, Mechanics and Control, vol. 30, Nr 2, 2011, s. 65-72
- [19] Holak K., Uhl T., Kohut P., Krupiński K., *Vision based condition assessment of structures*, 9th International Conference on Damage Assessment of Structures (DAMAS 2011), Journal of Physics: Conference Series 305, IOP Publishing, 2011
- [20] Holak K., Kohut P., Uhl T., Krupiński K., Owerko T., Kuraś P., *Structure's Condition Monitoring Based on Optical Measurements*, Key Engineering Materials, Vol. 518, s. 338-349.
- [21] Deraemaeker A., Preumont A., *Vibration based damage detection using large array sensors and spatial filters*, Mechanical Systems and Signal Processing, Vol. 20, Is. 7, 1615-1630, (2006)
- [22] Mendrok K., Uhl T.: *Modal filtration for damage detection and localization*, Proceedings of 4th EWOSH, Krakow, (2008)
- [23] Mendrok K.: *Simulation verification of damage detection algorithm*, Diagnostyka, Vol. 3, 17–23, (2010)
- [24] Mendrok K., Uhl T., *Overview of modal model based damage detection methods*, Proceedings of 2004 ISMA, Leuven, Belgium, (2004)
- [25] Zhang Q., Allemang, R.J., Brown, D.L., *Modal Filter: Concept and Applications*, Proceedings of International Modal Analysis Conference, pp. 487-496, (1990)
- [26] Meirovitch L., Baruh H., *Control of self-adjoint distributed parameter system*, Journal of Guidance Control and Dynamics, 8 (6), 60-66, (1982)
- [27] Mendrok K., Maj W.: “Laboratory tests of the SHM system based on modal filtration”, Diagnostyka, Vol. 1, 13–20, (2011)
- [28] Mendrok K., Uhl T.: *The application of modal filters for damage detection*, Smart Structures and Systems, Vol. 6, No. 2 115-133, (2010)



Ph.D. **Piotr KOHUT**, is an adjunct professor at the Department of Robotics and Mechatronics of AGH University of Science and Technology in Cracow. His scientific interests focus on mechatronics, vision systems, methods of image processing and analysis as well as 3D measurement techniques.



**DSc. Eng. Krzysztof MENDROK**

is a senior researcher in the Department of Robotics and Mechatronics of the AGH University of Science and Technology. He is interested in development and application of various SHM algorithms. He mainly deals with low frequency vibration

based methods for damage detection and inverse dynamic problem for operational load identification.



**M.Sc. Eng. Krzysztof HOLAK**

is Ph.D. student at the Department of Robotics and Mechatronics of AGH University of Science and Technology in Cracow. His works are connected with image processing, analysis and vision measurement systems.



**MSc, Eng. Wojciech MAJ**

is PhD student in the Department of Robotics and Mechatronics of the AGH University of Science and Technology. The main areas of his interest are digital signal processing and parallel computing architectures.